

# Unidades de mecanizado CNC Unità operatrici CNC

 EMPUJE  
SPINTA

9700 N

 PESO

140 Kg

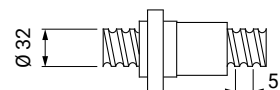

CAPACIDAD EN ACERO R=60  
CAPACITÀ SU ACCIAIO R=60

Ø 38/ M40

CARRERA  
CORSIA

160 mm

HUSILLO  
MANDRINO

T= ISO 40

VELOCIDAD HUSILLO / GIRI MANDRINO (50Hz)

A	160		
B	200	R6P	CADENA CON REDUCTOR
C	250		
D	300		
E	400	R4P	CATENA CON RIDUTTORE
F	500		
G	600		
H	800	6P	
I	1000		
J	1200		
K	1500	4P	CORREA DENTADA
L	1800		
M	2000		CINGHIA DENTATA
N	2400		
O	3000	2P	
P	3600		
Q	4000		

**DXE 42 /160 /.. /.. /..**

MOTOR / MOTORE

207	=	100	-	3,00 kW	2P
407	=	100	-	2,2 kW	4P
609	=	112	-	2,2 kW	6P

Tamaño máximo 112 / Grandezza massima 112

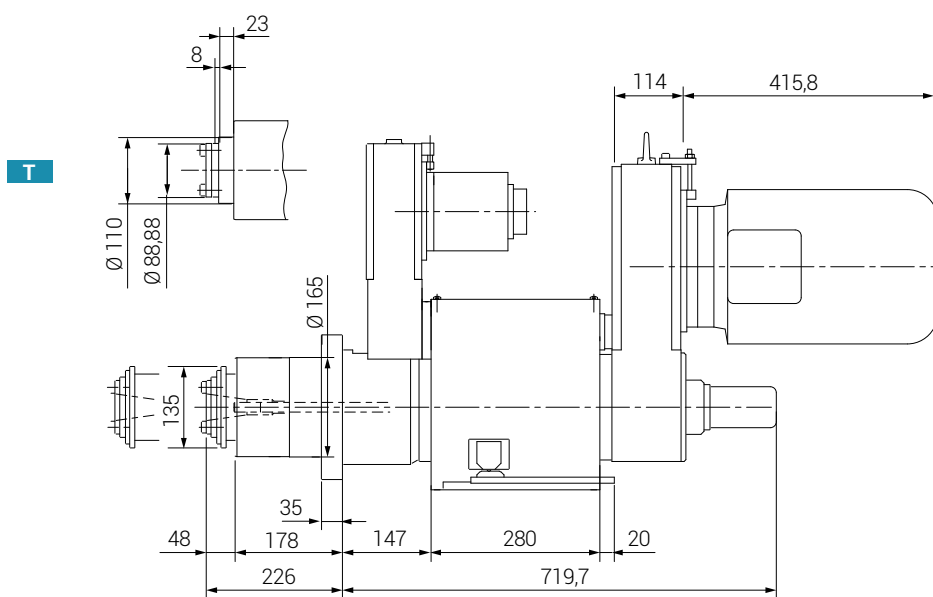

## ACCESORIOS

- Cabezales multihusillo
- Adaptación del motor servo
- Adaptación del motor del husillo

## ACCESSORI

- Teste multiple
- Predisposizione per motore avanzamento
- Predisposizione per motore rotazione mandrino