

● **Serie BX**

- Cilindri pneumatici a doppio effetto
- Passaggio refrigerante

Opzione per dispositivo di sicurezza pneumatico (vedi pag. 66)

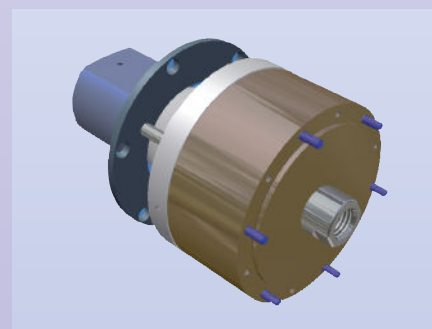

		BXO	BXN	BXP
Ø Pistone	mm	101	155	190
Superficie spinta	cm ²	65	175	275
Pressione max	bar	7	7	7
Velocità max	rpm	1500	1500	1500
Forza max spinta	N	4450	12000	18800
Peso	kg	3.2	5.3	7.5
N. rifer. flangia	—	1227	1227	—

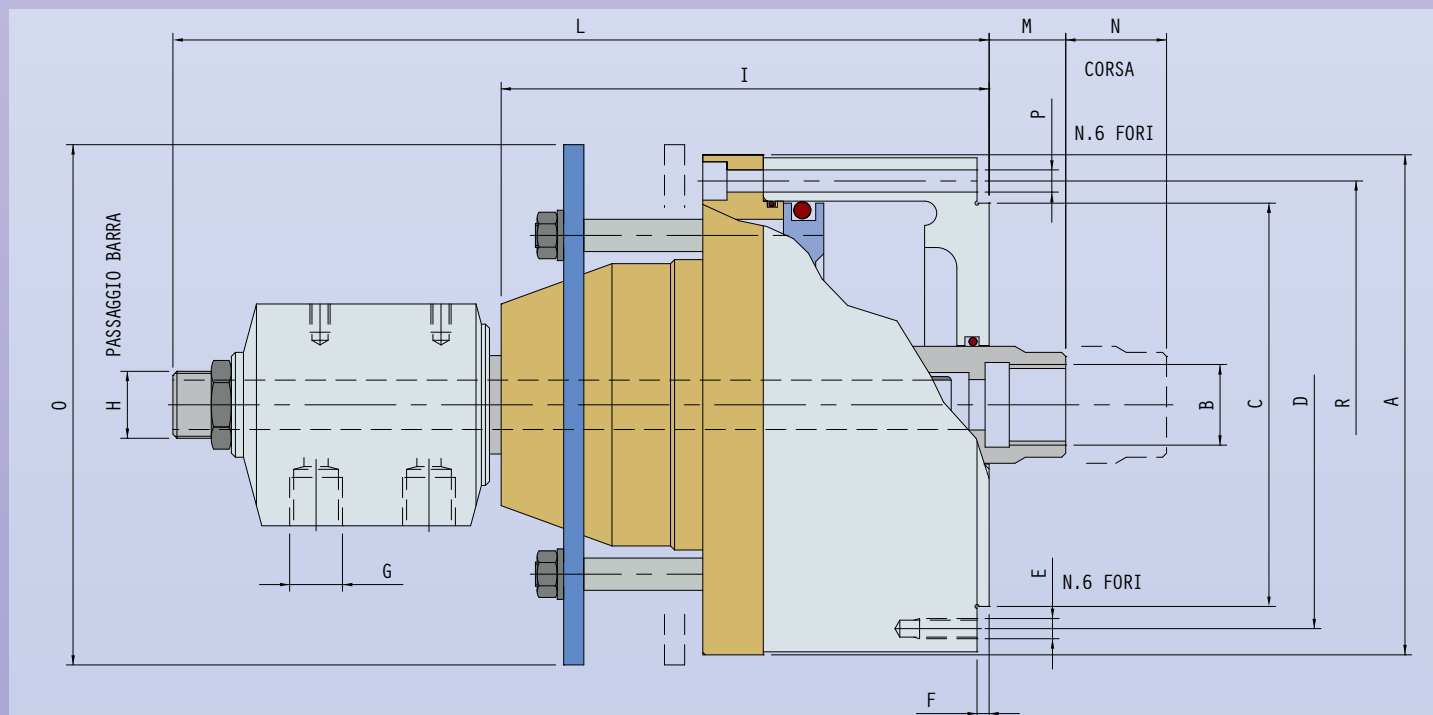

		BXO	BXN	BXP
A	mm	124	179	214
B	mm	M20x2.5	M20x2.5	M20x2.5
C g6	mm	100	100	100
D	mm	111	111	111
E	mm	M5	M5	M6
F	mm	3	3	3
G	mm	G 1/4"	G 1/4"	G 1/4"
H	mm	12.25	12.25	12.25
I	mm	121	125	125
L	mm	198	202	202
M	mm	19	19	19
N	mm	25	25	25
O	mm	129	129	129
P	mm	5.5	6.5	5.5
R	mm	111	165	200