

# Unidades de mecanizado Mandrini motorizados

 CARGA AXIAL MAX.  
CARICO ASSIALE MAX.

15000 N

 PESO

120-130 Kg

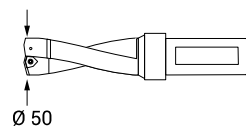

## VELOCIDAD HUSILLO / GIRI MANDRINO (50Hz)

A	160	
B	200	R6P
C	250	
D	300	
E	400	R4P
F	500	
G	600	
H	800	6P
I	1000	
J	1200	
K	1500	4P
L	1800	
M	2000	
N	2400	
O	3000	2P
P	3600	

CADENA CON  
REDUCTOR  
CATENA CON  
RIDUTTORE

CORREA  
DENTADA  
CINGHIA  
DENTATA

CAPACIDAD EN  
ACERO R=60  
CAPACITÀ SU  
ACCIAIO R=60

Ø 50

## MOTOR / MOTORE

207	=	100	-	3 kW	2P
407	=	100	-	2.2 kW	4P
609	=	112	-	2.2 kW	6P

Tamaño máximo 132 / Grandezza massima 132

## HUSILLO MANDRINO

TL = ISO 40 DIN  
69871 - LONG

**DX 38L /.. /.. /.. /.. (S)**

## RODAMIENTOS / CUSCINETTI

RC = Rodillos cónicos / Rulli conici  
CO = Dos pares contactos oblicuos / Doppia coppia a contatti obliqui

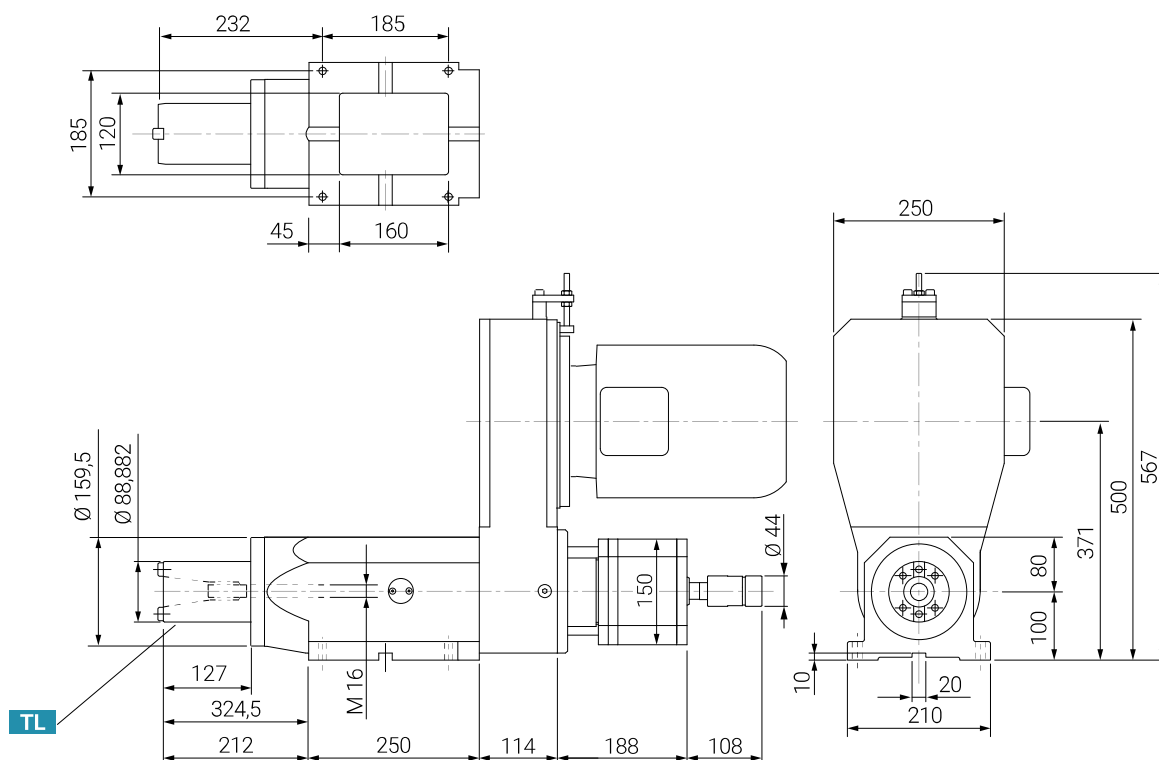

## OPERACIONES PERMITIDAS OPERAZIONI CONSENTITE

- Taladrad / Foratura
- Roscarado / Maschiatura
- Aburrido / Alesatura
- Quemado / Svasatura

## COMPONENTES OPCIONALES COMPONENTI OPZIONALI

- Preparación para servomotor /  
Predisposizione per servomotore
- Paso de refrigerante /  
Passaggio refrigerante